

Speake & Co Llanfapley
6, Firs Road * Llanfapley * Abergavenny * Monmouthshire * NP7 8SL * U.K.
Tel/Fax 01600 780150 *
email * billspeake@btconnect.com

FGM-series **Magnetic Field Sensors**



Application Notes

SCL004 Integrated Circuit - Self Calibrating Compass

This chip is intended to provide, with only a few additional components, all the features required to make a one degree indicating-precision compass when used in conjunction with an FGM-2 type sensor.

It has been programmed with the algorithms described in the SCL application note entitled "Autocalibration algorithms for FGM type sensors" to allow it to continuously remove the effect of the zero offsets and sensitivity variations of the sensor with which it is used.

It also has an externally programmable, orthogonality adjustment feature to permit correction for the small amount by which the individual sensors may not be truly at right angles to one another.

These two features, used properly will usually achieve a one degree accuracy though SCL only claims a two degree accuracy for this product. Other factors can give rise to greater errors and it is important to pay attention to them in setting up a system. They are described in more detail later.

The direction of increasing degree count can be set either clockwise or anti-clockwise allowing the sensor to be mounted upside-down (pins up) if this is more convenient.

To avoid waiting, after power-up, for a sufficient degree of rotation to trigger an auto calibration before readings are available, a system of storing the correction factors in an external EEPROM is provided. The auto calibration data, from a previous period of use, provides immediate readings during the wait for an initial calibration calculation.

Another selectable feature permits the use of the long term average of the calibration factors, rather than the most recently determined set. The averages are also stored in the EEPROM if this feature is in use.

The output from the chip is via an RS232 compatible serial port. The levels are TTL or 5 volt CMOS compatible and over short distances can usually be used directly, but are better fed to a standard RS232 interface chip for long distance transmission. An external control permits inverting the outputs for convenient interfacing. Baud rates from 1200 to 9600 are pin programmable.

Two different types of output are available, selectable by DIP switch or signal line from a computer or microcontroller. One is an angular reading in degrees in the format 00nnn(CR), where nnn are the three digits of the 360° heading, preceded by two zeros and followed by a carriage return. The other is in Cartesian form, giving corrected X and Y values of the sensor field components, in the format ±0xxxx,±0yyyy(CR)

The latter format allows the user to carry out his own alternative processing of the basic corrected sensor data, rather than using the chip's internal trigonometric routines, adding linearity corrections, etc. or even using the data for some other purpose entirely.

An additional type of output is available, for those who do not wish to use a computer or other RS232 link, in the form of a serial feed to a direct digital display. This output can be employed simultaneously with the RS232 link.

Pin Layout

| | | | |
|----|---------|------------|----|
| 1 | MCLR | RS232 INV | 40 |
| 2 | XSENS | AVERAGE | 39 |
| 3 | YSENS | ALONE | 38 |
| 4 | NC | POLAR/CART | 37 |
| 5 | NC | FLIP | 36 |
| 6 | NC | ORTH SGN | 35 |
| 7 | NC | ORTHOG1 | 34 |
| 8 | EDCLK | ORTHOG0 | 33 |
| 9 | EDDATA | VDD | 32 |
| 10 | EDENB | VSS | 31 |
| 11 | VDD | NC | 30 |
| 12 | VSS | NC | 29 |
| 13 | XTAL1 | NC | 28 |
| 14 | XTAL2 | NC | 27 |
| 15 | BAUD0 | TX | 26 |
| 16 | BAUD1 | RTS | 25 |
| 17 | LCD/LED | CTS | 24 |
| 18 | SCLK | SDATA | 23 |
| 19 | DEC | NC | 22 |
| 20 | INC | SCL004 | NC |
| | | | 21 |

PIN CONNECTIONS

Pin Functions

Pin 1: MCLR

Chip reset pin which clears internal registers and restarts the autocalibration process. It can be tied directly to Vdd or via a resistor (10K to 47K) to Vdd for external control.

Pin 2: XSENS

X sensor input pin and should be connected directly to the output of an FGM series sensor.

Pin 3: YSENS

This is the corresponding Y sensor input.

Pins 4-7 : NC

No connection pins, reserved for future use, and should be left open circuit.

Pin 8 : EDCLK

Driving clock for the serial link to a digital display. Suitable displays are the LED type TSM6755 from Three-Five Systems Inc. and the LCD type DDM4 from Lascar Electronics Ltd.

Pin 9 : EDDATA

Data input for the serial link to digital display.

Pin 10 : EDENB

Data enable line for the serial link to digital display.

Pins 11, 32 : VDD

Vdd supply pins, connected to +5 volt supply. These should be adequately decoupled to Vss, close to the pin connection. (47nF capacitors)

2

- Pins 12, 31 : VSS
Vss or GND connection pins.
- Pins 13, 14 : XTAL1, XTAL2
Connection for external crystal or ceramic resonator coupling to internal oscillator. (4MHz)
- Pins 15, 16 : BAUD0, BAUD1
Baud rate control pins for the RS232 output. These should be connected to Vdd or Vss or to resistors to Vdd and external control levels or switches. (10K-47K)
The baud rates are selected by binary coding (0 volts/low, 5 volts/high) as follows:
- | | |
|----|-----------|
| 00 | 1200 baud |
| 01 | 2400 baud |
| 10 | 4800 baud |
| 11 | 9600 baud |
- Pin 17 : LCD/LED
Connect to Vdd to use the LCD type serial display and to Vss for the LED versions.
- Pin 18 : SCLK
Clock driver pin for I²C interface to EEPROM used for storage of autocalibration parameters during power off periods. This interface is not essential for operation and pins should be left open circuit if not used.
- Pins 19-20 : DEC, INC
Schmitt trigger type pulse input pins which decrement or increment both the RS232 angular output and the digital display reading. The number of steps input during this process is stored in the EEPROM. Simultaneous pulses to both pins resets this number to zero.
- Pins 21-22 : NC
No connection pins, reserved for future use, and should be left open circuit.
- Pin 23 : SDATA
Data line for I²C interface to EEPROM.
- Pin 24 : CTS
Clear to Send input pin for RS232 compatible output interface. This pin **must be taken high** via a resistor to Vdd (10K-47K) if not used.
- Pin 25 : RTS
Request to Send output pin For RS232 compatible interface. Leave open circuit if unused.
- Pin 26 : TX
Data send pin for RS232 compatible interface. Leave open circuit if unused.
- Pins 27-30 : NC
No connection pins, reserved for future use, and should be left open circuit.
- Pins 33, 34 : ORTHOG0, ORTHOG1
Control pins for correcting non-orthogonality error in sensor assembly. These pins should be connected directly to Vdd or Vss for external control by level or switch. If left open circuit an internal pull-up takes them to Vdd without the need for external resistors. The corrections are programmed in binary levels (0 volts/low, 5 volts/high) as follows:
- | | |
|----|---------------|
| 00 | no correction |
| 01 | 4 degrees |
| 10 | 2 degrees |
| 11 | 1 degree |
- Pin 35 : ORTHOG SGN
The level on this pin alters the sign of the non-orthogonality correction. No pull-up resistors are required.
- Pin 36 : FLIP
The level on this pin changes the direction of increasing angle around the circle. (high/clockwise, low/anticlockwise with the sensor mounted pins down). No pull-up resistors are required. This permits a normal direction of rotation to be obtained with the sensor mounted upside down.

Pin 37 : POLAR/CART

The level on this pin controls the type of data sent by the RS232 compatible output. No pull-up resistors are required.

One form of output is an angular reading in degrees in the format 00nnn(CR), where nnn are the three digits of the 360° heading, preceded by two zeros and followed by a carriage return. This is obtained with a high input to the pin.

The other is in Cartesian form, giving corrected X and Y values of the sensor field components, in the format ±0xxx,±0yyyy(CR) and is obtained when the input to the pin is low.

Pin 38 : ALONE

This pin should be left open circuit if no EEPROM is used for parameter storage (stand alone mode) and taken low for use with an external EEPROM.

Pin 39 : AVERAGE

If this pin is left open circuit, the long term average of a number of autocalibrations is used to set the sensor parameters. If it is connected low, it forces the most recent autocalibration to be put into effect.

Pin 40 : RS232 INV

When taken high this pin inverts the TX, RTS and CTS signal lines for use with inverting RS232 drivers.

Typical Full Configuration

A completely configurable system is shown below.

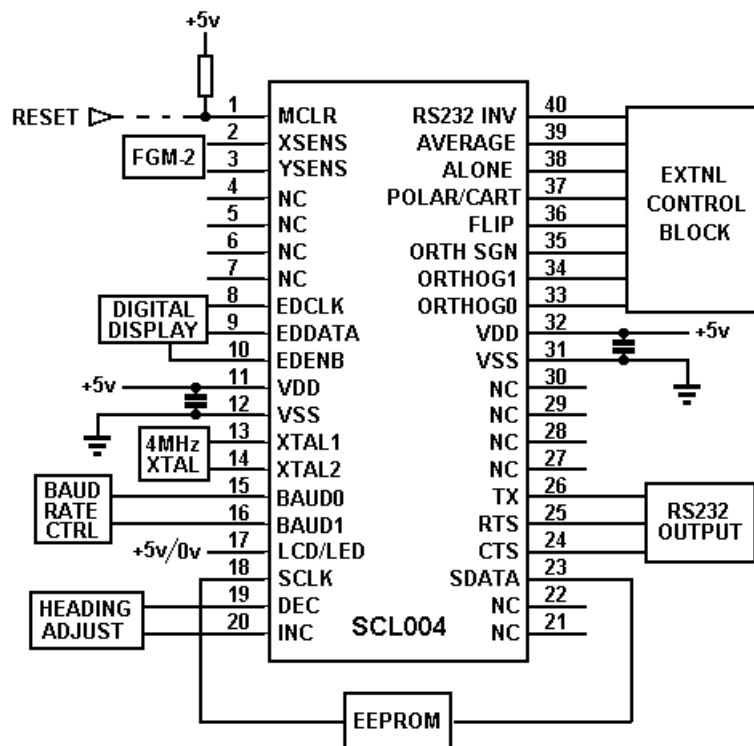

Typical Hardware Configuration

The individual interface blocks are detailed in subsequent diagrams. It is not necessary to make use of all the configurable features at any one time. If a set of fixed conditions is all that is required then the control pins can be directly wired high or low as needed to set up those conditions. This will reduce the external component count and simplify the layout.

RESET

This can be taken directly to +5 volts or via a resistor as shown. Reset will occur on power-up and can be initiated subsequently by an incoming TTL or CMOS signal which goes temporarily to ground or by manual push button to ground.

Sensor Interface

This is as shown below.

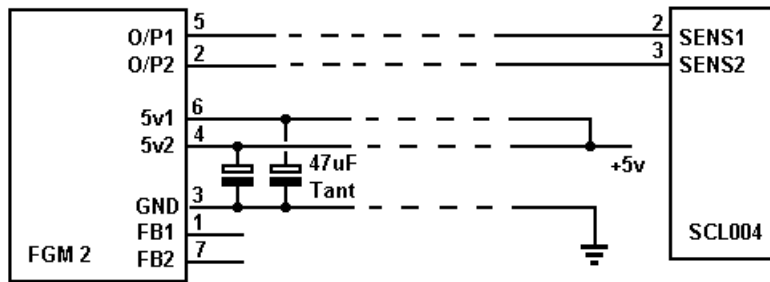

SENSOR CONNECTIONS

Common supply line impedance can give rise to a tendency for the individual sensors to lock together over short bands of their range. This can be eliminated by decoupling capacitors fitted close to the sensor pins. Separate supply lines are provided for each +5 volt rail and if long leads are used to the sensor, more effective decoupling is obtained by running these lines separately back to the supply source.

External Crystal Circuit

A crystal or ceramic resonator oscillating at 4 MHz is required as shown below.

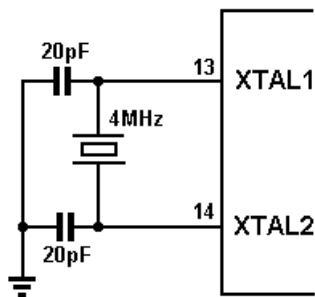

CLOCK CIRCUIT

Baud Rate Control Interface

A switchable rate system is illustrated below.

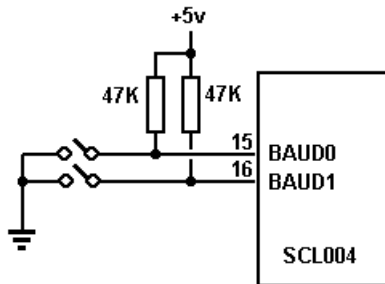

BAUD RATE CONNECTIONS

The rate can also be controlled by TTL or CMOS input from an external source and if only one fixed baud rate is required then the pins may be directly wired to +5 volts or ground as appropriate.

RS232 Interface

A full voltage specification interface is shown below, using an inverting RS232 driver chip.

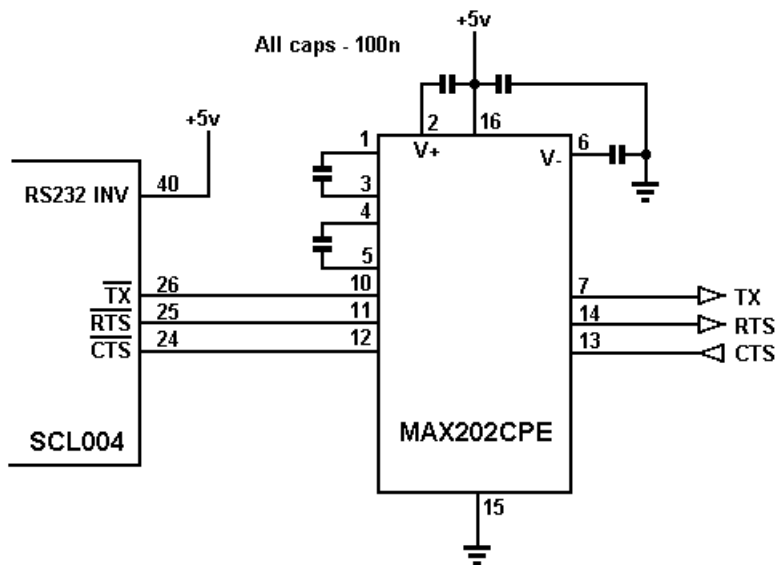

RS232 SPEC DRIVE INTERFACE

This type of interface is recommended where long lines will be used to connect the serial link. It is also necessary to take pin 40, RS232 INV high on the SCL004 chip if inverting drivers are to be used.

Over modest length signal lines, to a PC or microcontroller, a simpler interface will suffice.

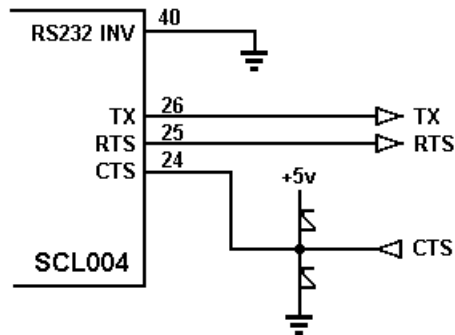

SIMPLE RS232 INTERFACE

In this configuration pin 40 on the SCL chip must be grounded.

It is not necessary to use the RS232 interface if the direct digital display is employed, but in this case, **pin 24 (CTS) must be connected high to avoid the chip stalling.**

External Control Block

This block of controls affects the way in which various functions of the chip are employed and can be set by external TTL or CMOS levels from other equipment, dual-in-line switch or hard wired connections if fixed conditions are acceptable. A typical switched configuration is shown below. These may be changed at any time with the exception of AVERAGE, which is only read correctly on power-up or reset. Subsequent changes should be followed by a chip reset to avoid malfunction of the averaging process.

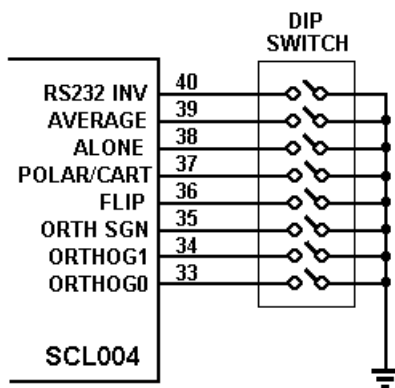

EXTERNAL CONTROL CONNECTIONS

RS232 INV

This has already been covered in earlier material.

AVERAGE

A high level on this pin forces the chip to use long term averages of both zero offset and scale factor to be used in the computation of angles, rather than the values which have come from the most recent re-calibration. This is useful for systems in which the sensor is gimbaled to overcome the effects of tilt and acceleration in the vehicle or vessel in which the sensor is installed. Momentary displacements in tilt are inevitable in such set-ups but the longer term averages of sensor position more nearly correspond to a level condition. This may be helpful in reducing the instantaneous tilt errors which will otherwise occur continuously, disturbing the proper operation of the autocalibration algorithms.

The SCL004 is essentially intended as a bolt-down orientation device, but if it is gimbaled it may still provide a reasonable performance in many cases.

ALONE

A high level on this pin sets the chip into stand alone mode in which it will not provide data until it has carried out an autocalibration. This calls for some rotation in orientation before readings are available, usually not a problem in motor vehicles, for example, which tend to manoeuvre significantly immediately after start-up. If readings are required immediately after powerup then a low level on this pin will cause the chip to seek a set of parameters from an EEPROM in which the last calibration has been stored. If an EEPROM is in use the chip always stores its most recent calibration for subsequent use and this data is not lost during power-down.

POLAR/CART

This has already been covered in earlier material. A high level on this pin gives the angular reading, a low giving the X,Y values of the normalised field.

FLIP

A high level on this pin gives a clockwise rotation to increasing angle when the sensor is in the pins down position. A low level reverses this direction.

ORTHO SGN

This bit controls the direction in which the orthogonality correction is applied, clockwise or anticlockwise.

ORTHO0, ORTHO1

These bits can be programmed to give the magnitude of the orthogonality correction as described earlier. The size and direction of these corrections can only be found experimentally. A simple method is to compare the north/south readings with the east/west readings. These should show an average difference of 90°. The extent to which they do not is a measure of the direction and magnitude of the orthogonality error. The control pins can then be programmed to minimise this error, preferably spreading the error evenly between the four cardinal points of the compass.

Heading Adjustment Interface

DEC, INC

Individual pulses on these two pins permit the user to decrement or increment, by one degree steps, both the RS232 angle output and the digital display reading. Both inputs are Schmitt trigger types and can be used with TTL signals or switch contacts.

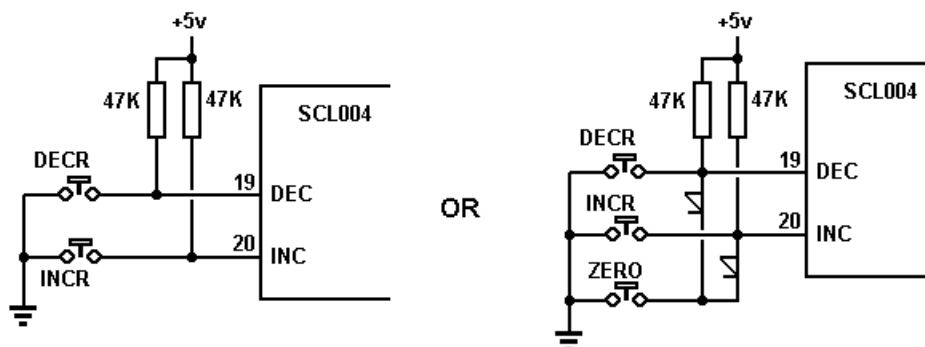

HEADING ADJUST CONNECTIONS

The purpose of this adjustment is to easily correct for any errors made in the initial alignment of the sensor with the desired pointing direction. This obviates the necessity for subsequent mechanical adjustments in pursuit of calibration "tweaking" on a sensor which may, by this time, be inconveniently accessible, (at the top of an aerial tower for example.)

It could also be used to switch between "true" and "magnetic" bearings, if required.

The correction factor, after adjustment, is stored in the EEPROM along with the other calibration parameters so as to make it available after subsequent power-downs. To reset the correction to zero, the INC and DEC buttons should be pressed and released simultaneously.

EEPROM Interface

A suitable arrangement for storing the last calibration parameters is shown below. The process is automatic, no other action being required apart from setting the ALONE bit low.

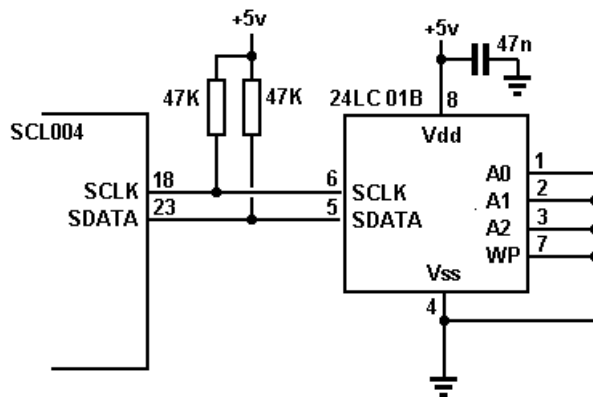

EEPROM CONNECTIONS

Direct External Digital Display

An interface is provided for immediate display without the use of a PC or microcontroller system in the shape of a serial data stream of 7-segment data for appropriate displays. Suitable types are the Three-Five systems Inc. or Lascar Electronics modules described earlier. The format is as described in the specification sheets for these devices and could be exploited by other circuitry.

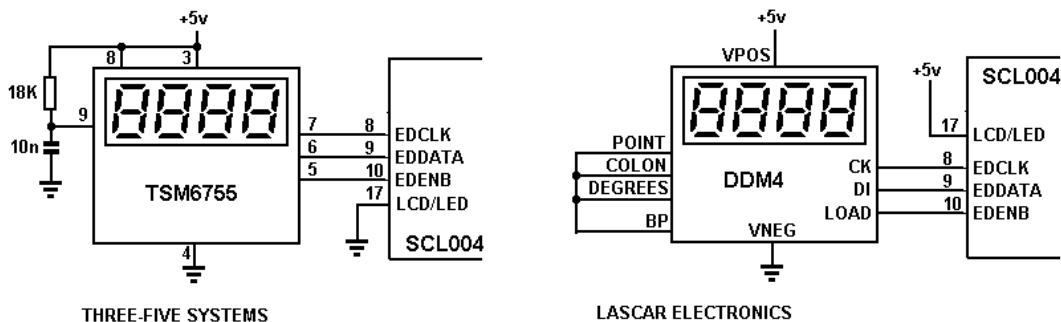

SERIAL DISPLAY CONNECTIONS

Application to Compass Design

Although originally designed for use in bolt-down orientation applications, such as rotating aerials, etc., if the sensor is mounted in a suitable gimbaling system designed to maintain a mean level attitude, the chip can be used for conventional compass designs. Because tilt from a level attitude has a marked effect on such sensor systems, some information on this is provided in what follows, both as regards bolt-down and gimbaled systems.

The influence of the autocalibration algorithms in the presence of tilt is also examined.

Basic Tilt Effect

In most regions of the earth's surface the magnetic field vector is at an angle to the local horizontal plane and it is this which gives rise to the problems associated with tilt in compass sensors.

In the temperate latitudes, this dip angle is commonly very large. In the United Kingdom, for example it is around 67° to the horizontal. It also points acutely downwards to the north which leads to rather awkward looking three dimensional diagrams. For an open axis view point the XY plane should be viewed from below and projections to the horizontal plane go upwards, leading to an unfamiliar look to the vector diagrams.

For the sake of more familiar visualisation, all subsequent diagrams are shown as for a southern hemisphere location of equivalent latitude, with an upward pointing field vector to the north. Other simple geometric tricks are also used where appropriate to ease the visualisation process, such as always drawing the sensor axes as horizontal ones. For tilt, the world is tilted in the opposite direction instead. In place of tilting the sensor the field vector is given an opposing tilt. The geometry is relative and the results are the same, but some simplification of the diagrams is usually possible.

A compass sensor which is assumed to lie in the horizontal plane will see quite large changes, therefore, in its projected horizontal components if it moves out of that plane, because the components are quite small to start with.

Not all of these changes have an influence on the final result however.

If an orthogonal pair of sensors are aligned (horizontally) so that one of them (Y, say) lies in the north/south direction and the other (X) in the east/west direction, then a tilt along the north/south line (ie a rotation about the east/west axis) has no effect on the compass bearing calculated from the sensor readings.

The reason for this is that the Y component is finite and varies with the tilt, but the X component is zero. A bearing computed from the arctangent of X/Y is always zero degrees regardless of the value of Y, as long as it does not itself go to zero. So no error occurs even for large tilts.

However, for tilt along the east/west line (ie a rotation about the north/south axis) produces a finite value of the X component and a finite bearing error. Worse still a small tilt gives quite a large value to the X component if the dip angle is large, so the bearing error is much larger than the tilt angle. This is illustrated in the diagram overleaf in which the sensor is shown horizontal and the world rotated around the north/south axis.

For this sensor alignment, the bearing error, ϵ is

$$\epsilon = \arctan(\tan\psi\sin\theta)$$

where ψ is the dip angle and θ is the tilt angle.

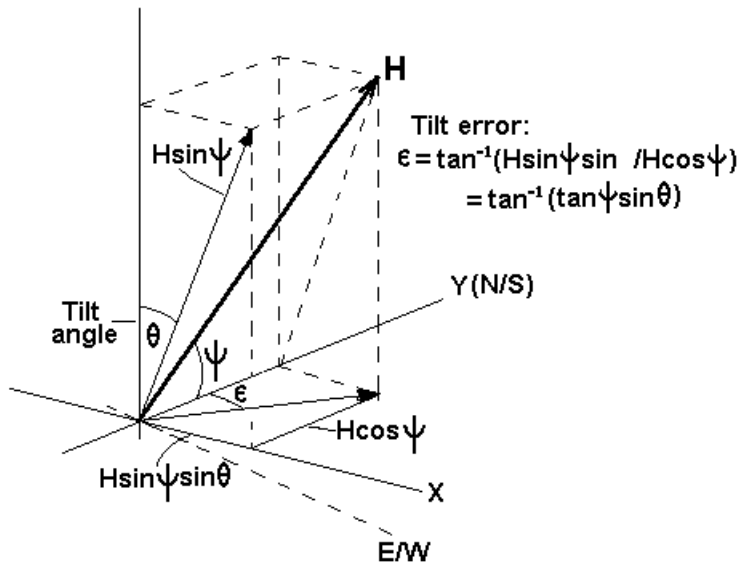

Tilt along east/west line

For the previously quoted dip angle of 67° this gives a bearing error of 2.35° for a tilt of 1°

The rate at which the bearing error increases with tilt gets smaller as the tilt increases up to a maximum error of 67° when the tilt is 90° as illustrated in the graph which follows.

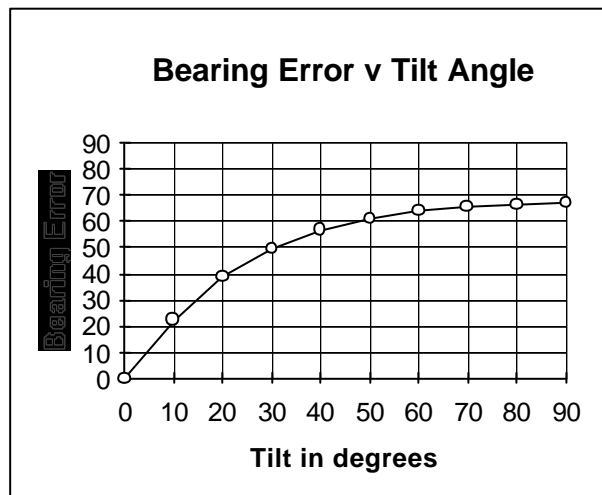

For tilt along a line between these two extremes, a similar pattern of error occurs but with a smaller overall scale. Along a line close to the north/south direction tilt causes small errors. Along a line close to the east/west direction tilt causes much larger errors and there is a smooth transition from large errors to small ones as the line of the tilt moves around the horizontal plane.

In fact it is really only the east/west tilt which causes the problem and the easiest way to deal with this is to resolve any tilt, like a vector into two components, one along the north/south direction and the other along the east/west direction. The north/south component can be ignored, since we know it has no effect, the east west component being used on its own to determine the bearing error.

The tilt angle cannot be resolved directly. What is resolvable as a vector is the slope which results from the tilt, but since this is just $\tan\theta$ where θ is the tilt angle, the trick is to take the tangent, do the resolution and then take the arctangent of the components to get the resolved angles.

So, for example, if the maximum tilt line is along a line at angle ϕ to the north/south direction, the east/west component of tilt is

$$\theta_{ew} = \arctan(\sin\phi\tan\theta)$$

and the north/south component is

$$\theta_{ns} = \arctan(\cos\phi\tan\theta)$$

The analysis so far has been in terms of a sensor system in which the Y axis sensor is aligned north/south. In fact it does not matter which direction the sensors are oriented, the result is the same and only depends on the tilt in the magnetic east/west direction.

Bolt Down Applications

In bolt-down applications there are two different basic kinds of tilt, as follows;

- a) Those in which the sensor plane is truly parallel to the rotation plane but the latter is not truly horizontal.
- b) Those in which the rotation plane is truly horizontal but the sensor plane is tilted with respect to the rotation plane.

Case a) Sensor parallel to a tilted rotation plane

This is equivalent to the situation illustrated previously, in which the sensor plane is horizontal, the rotation axis vertical but the world and field vector tilted sideways giving the previous calculated bearing error.

A little consideration will also show that it is no different to the ideal situation of a horizontal sensor and vertical rotation axis, except that the field vector now has a slightly smaller dip angle and no longer points precisely along the north/south line.

Another visualisation trick is to rotate the world around the sensor rather than rotating the sensor in considering the compass behaviour. The field vector traces out a cone in space as illustrated below.

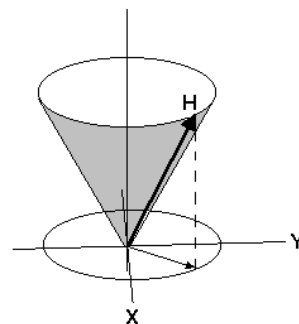

Case a)

The projection of the cone on to the XY plane of the sensor is a perfect circle which implies that the indicated compass angles will be correctly and evenly spaced, but will show a fixed error,

related to the tilt, around the whole 360° of rotation. This is not a disaster since the sensor will normally be aligned in a direction which gives the desired reading during initial

12

installation. It may be set up, for example, to read true north rather than magnetic north for the location in question.

Of interest also is the effect all of this has on the operation of the autocalibration algorithms used by the chip software. Since the situation described above is little different from normal compass operation, the algorithms continue to work correctly in eliminating any zero offsets and scale errors encountered, as accurately as they would in ideal circumstances. However they have no way of becoming aware of the bearing error and make no attempt to correct it.

Case b) Sensor tilted with respect to a horizontal rotation plane

This is slightly more difficult to visualise, but using the same technique as before, if the sensor is considered to be stationary, the world is rotated about a vertical axis and the sensor plane is then tilted down to be horizontal, a little consideration will show that it is the same as the previous case, but with the cone tilted with respect to the sensor, as illustrated below.

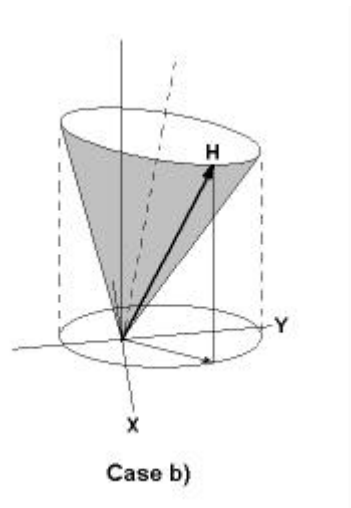

The projection of the field vector tip path on to the sensor plane can be seen to be an off-centred ellipse.

This is exactly what the chip sees coming from a raw, uncorrected sensor with its massive zero offsets and unbalanced scale factors, except that the errors arising from tilt are much smaller. In consequence these smaller errors are swallowed up by the autocalibration algorithm and eliminated along with the raw sensor errors. The projection on to the XY plane is effectively reduced to a perfect circle and the compass behaves as if the tilt did not exist. The autocalibration not only functions correctly in the presence of tilt, it also removes the effect of tilt.

This can be experimentally demonstrated to occur even for very large tilts giving even larger bearing errors initially.

As a consequence of this property of the autocalibration procedure, it is not necessary to take great care in the level mounting of the sensor in bolt-down type applications. An initial north south alignment is all that is required during the setting up procedure.

Gimballed Sensor Considerations

The above discussion only applies to the bolt-down type of sensor mounting, where the sensor is constrained to rotate in a fixed plane, albeit not necessarily horizontal. This is necessary for the autocalibration to work.

An alternative to the bolt-down arrangement, to permit some tilting to the carrying platform or vehicle, is a gimballed or pendulous sensor. Provided that the axis of rotation remains vertical, which it does in such arrangements, the system is the equivalent of case b) discussed above. The sensor may not be truly horizontal but the effects of that tilt will be removed as before. It is not therefore necessary to take great care that the sensor hangs level as it is in most normal gimballed systems, again an advantage in ease of setting up.

Since in platform motion the rotation axis may not always be absolutely vertical, individual calibrations may suffer from momentary errors. However since the mean position over a longer period will approximate the vertical better than any instantaneous position, it is best to use the chip mode which makes its corrections by using the long term averages of the parameters, for gimballed systems. While not perfect, this approach should improve the accuracy of the final output.

Effects of magnetic material disturbance

The following material is an extract from the latest version of the application note covering the theory and use of the autocalibration algorithms.

"An even more interesting property of the algorithms, which was neither sought after nor even appreciated originally, is their ability to make surrounding magnetised or magnetisable material virtually disappear from the view of the orientation determining device.

For a compass this means that the ship or vehicle in which it is installed vanishes, as far as causing deviations is concerned. While this is not totally true as will be seen later, it appears to be correct for any reasonably careful installation down to third order effects and even for a bad installation it should effect a major improvement.

Acknowledgement is given here to W. Denne (Extra Master, F. Inst. Nav., Assoc. R.I.N.A.) for the background information and theory on which this analysis of effects is based.

For the purpose of the analysis, two types of interfering material are considered, the first being magnetised material, by which is meant anything which has acquired a degree of remanent magnetisation. This is magnetically "hard" material with a reasonably high coercivity which has become magnetised by some event in its history and retains this magnetisation, much like a deliberately fabricated permanent magnet. This type of magnetisation can occur during such processes as arc welding during construction and generally does not change much subsequently.

The second type is magnetisable material, by which is meant anything which can acquire a temporary magnetisation as a result of being in a magnetic field. This is magnetically "soft" material with a low coercivity but reasonably high permeability, allowing it to magnify any local fields which surround it to much higher values. Such material will produce temporary magnets as a result of the earth's field, for example.

These two types, either singly or in various combinations, account for all the interfering fields experienced by a compass installation and are described by Denne using the following notation.

X, Y and Z represent the true components of the earth's field, X being in the forward direction of the vehicle, Y being in the transverse direction to the right (or starboard) and Z being vertical.

X', Y' and Z' are the disturbed components as seen by the compass, using the same directional significance.

The disturbed values can be expressed in terms of the true values by the following equations:

$$\begin{aligned}X' &= X + aX + bY + cZ + P \\Y' &= Y + dX + eY + fZ + Q \\Z' &= Z + gX + hY + kZ + R\end{aligned}$$

where the coefficients a to k are attributable to errors arising from the "soft" material being magnetised by the earth's field and P,Q and R are deviations caused by the permanent "hard" material.

Rearranging the terms, we get:

$$\begin{aligned}X' &= X(1 + a) + P + bY + cZ \\Y' &= Y(1 + e) + Q + dX + fZ \\Z' &= Z(1 + k) + R + gX + hY\end{aligned}$$

The first term in each of these equations represents a variation in the amplitude of the field component or in other words, a sensitivity variation in the measurement.

The second term in each equation is an added offset to the field value, exactly that which we have described as a zero offset previously. If the remaining two terms in each equation were zero, negligible or could be removed algorithmically like the others, then the effect of the disturbing material would be eliminated completely.

It has not proved simple to remove these remaining terms algorithmically, so it is of interest to examine them by a physical interpretation. In any magnetisable body the direction of magnetisation arising from an external field would generally be expected to have the same direction as the field causing it. For example, in a spherical, totally isotropic piece of soft iron, the direction of magnetisation caused by the earth's field would align itself precisely with the earth's field. In this case the cross-axis effects would not exist and coefficients such as b,c,d,f,g and h would be zero.

For shapes which are increasingly less symmetrical, then shape dependent demagnetisation would give rise to some tendency to depart from true alignment of field and induced magnetisation, leading to finite values for the cross-axis coefficients. Nevertheless, for all but peculiarly shaped objects, such as long thin bodies, we would argue that the departure from alignment would represent an order lower effect than the main axis effects.

Magnetic anisotropy could also give rise to similar alignment errors but again for all but highly anisotropic materials, should give rise to an order lower errors. Provided the initial installation is carried out with some consideration of such errors, it would seem that the cross axis effects could be of a lower order than the main deviations.

In any case, a considerable improvement in performance might be anticipated from use of the auto calibration algorithms in most cases."

Experimental verification of this effect has been obtained and shows the cross axis effects to be minor as anticipated.

References

Magnetic Compass Deviation and Correction by W. Denne
Brown, Son & Ferguson, Ltd., Glasgow G41 2SG
ISBN 0 85174 332 3

SCL004A : CALIBRATE-ON-DEMAND VARIANT

This version of the SCL004 chip is identical to the standard version in all respects except for the function of the stand-alone input, pin 38.

This pin is used instead to switch off the autocalibration function after a satisfactory calibration has been achieved. For gimballed systems, in which fairly severe tilting or swinging may be encountered from time to time, this may prove to be a better approach than averaging the autocalibration parameters. The system should be calibrated, using the autocalibration technique in ideal level conditions, the autocalibration being switched off after this, for subsequent use.

Because the stand-alone feature is no longer available in this version, it must always be used with a supporting EEPROM.

A more important aspect, perhaps, is that electronic gimbaling can be applied to such two-axis systems but not if autocalibration is occurring at the same time. The A variant can exploit the more sophisticated electronic gimbaling techniques (which the standard bolt-down version cannot and does not need) but only at the expense of losing the continuous re-calibration which the standard bolt-down version benefits from.

This may be considered a small price to pay for the advantage of tilt correction, for example, in hand held devices.

It is still possible to use the A variant with continuous calibration for bolt-down systems, but an EEPROM must be provided in this case.

For the SCL004A the Pin Functions data should be replaced by the following:

Pin 38: CALSW

If this pin is left open circuit the autocalibration function is inhibited. If taken low autocalibration occurs continuously and stores averaged parameters in the EEPROM, for as long as the pin is held low. To obtain a good calibration for subsequent use, the system should be rotated in a level attitude while CALSW is low, preferably through several rotations to obtain a good set of averages.

Pin 39: This pin is no longer used and should be left open circuit.

